

SR02-GD2X 1U/2U Solid Bearing Sliding Rail Installation

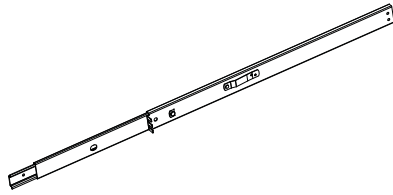

Included in this package

(2) 24" Sliding Rail



(8) M4 x 8 Screws



(8) #10-32 x 5/8 Screws



(8) #12-24 x 5/8 Screws



(8) M4 Hex Nuts



(2) Rear Mount 7" extension ear

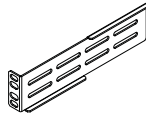

Installation Steps

- 1 Holding the 24" sliding rail on one hand then pull the traveling slide all the way out until it stops (you will hear a metal click sound). The circular shaped metal button should snap in place. If you need to push traveling slide back in, you have to push down the metal button then push. To fully detach the traveling slide, you have to push in the metal button and pull the traveling slide.

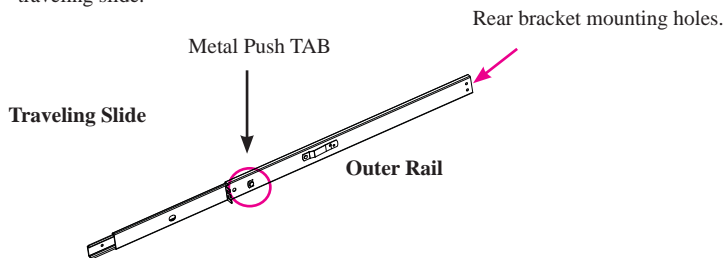

- 2 Mounting the rear 7" extension bracket as shown in the picture below. Adjusting the extension bracket according to the mounting position you need in your cabinet. Align OB slots on the extension bracket with the (2) mounting holes at rear of Outer Rail. Secure the 7" extension to Outer Rail with (2) M4 Screw and Nuts. Do not tighten M4 screws yet.

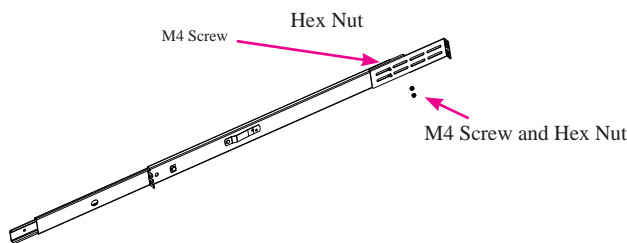

- 3 Place the reverse "E" shaped front bracket in front of the rack rail on your cabinet. Align front bracket with (2) rack mounting holes on the rack rail. Secure front bracket with 10-32 or 12-24 rack screws. Readjust the rear extension bracket depth accordingly. Secure rear extension bracket with (2) rack screw. Tighten all M4 screws on the extension bracket with hex nuts.

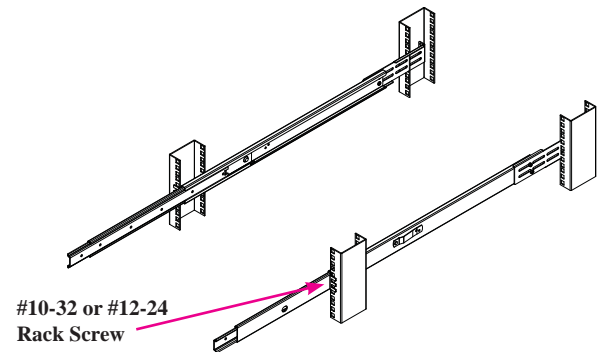

4. Repeat Step 1 to 3 for right hand side rail and ear bracket.